

**500-1400 VA
User's Manual**

User's Manual 500-1400 VA

1015715
Revision B

Table of Contents

1	Powerware 5115 — Introduction	5
	Special Symbols	6
2	Installation	7
	Inspecting the Equipment	7
	Safety Precautions	7
	Installing the UPS	7
	UPS Rear Panels	9
3	Operation and Configuration	10
	Turning the UPS On	10
	Starting the UPS on Battery	10
	Turning the UPS Off	10
	Standby Mode	10
	UPS Front Panel	10
	Initiating the Self-Test	11
	Voltage Configuration	11
4	Communication options	12
	Communication Port	12
	USB Port	13
	Network Transient Protector	13
5	UPS Maintenance	14
	UPS and Battery Care	14
	Storing the UPS and Batteries	14
	Replacing Batteries	14
	Testing New Batteries	15
	Recycling the Used Battery	17
6	Troubleshooting	17
	Audible Alarms and UPS Conditions	17
	Silencing an Audible Alarm	17
	Service and Support	19
	Warranty	19
7	Specifications	19

Class B EMC Statements

FCC Part 15

NOTE This equipment has been tested and found to comply with the limits for a Class B digital device, pursuant to part 15 of the FCC Rules. These limits are designed to provide reasonable protection against harmful interference in a residential installation. This equipment generates, uses and can radiate radio frequency energy and, if not installed and used in accordance with the instructions, may cause harmful interference to radio communications. However, there is no guarantee that interference will not occur in a particular installation. If this equipment does cause harmful interference to radio or television reception, which can be determined by turning the equipment off and on, the user is encouraged to try to correct the interference by one or more of the following measures:

- Reorient or relocate the receiving antenna.
- Increase the separation between the equipment and the receiver.
- Connect the equipment into an outlet on a circuit different from that to which the receiver is connected.
- Consult the dealer or an experienced radio/TV technician for help.

ICES-003

This Class B Interference Causing Equipment meets all requirements of the Canadian Interference Causing Equipment Regulations ICES-003.

Cet appareil numérique de la classe B respecte toutes les exigences du Règlement sur le matériel brouilleur du Canada.

Requesting a Declaration of Conformity

Units that are labeled with a CE mark comply with the following harmonic standards and EU directives:

- Harmonic Standards: EN 50091-1-1 and EN 50091-2
- EU Directives: 73/23/EEC, Council Directive on equipment designed for use within certain voltage limits
93/68/EEC, Amending Directive 73/23/EEC
89/336/EEC, Council Directive relating to electromagnetic compatibility
92/31/EEC, Amending Directive 89/336/EEC relating to EMC

The EC Declaration of Conformity is available upon request for products with a CE mark. For copies of the EC Declaration of Conformity, contact:

Powerware Oy
Koskelontie 13, FIN-02920 Espoo
Finland
Phone: +358-9-452 661
Fax: +358-9-452 66 396

©Copyright 2003.

The contents of this manual are the copyright of the publisher and may not be reproduced (even extracts) unless permission is granted. Every care has been taken to ensure the accuracy of the information contained in this manual, but no liability can be accepted for any errors or omission. The right to make design modifications is reserved.

1. Powerware® 5115 – Introduction

The Powerware 5115 uninterruptible power system (UPS) protects your sensitive electronic equipment from basic power problems such as power failures, power sags, power surges, brownouts, and line noise.

Power outages can occur when you least expect it and power quality can be erratic. These power problems have the potential to corrupt critical data, destroy unsaved work sessions, and damage hardware — causing hours of lost productivity and expensive repairs.

With the Powerware 5115, you can safely eliminate the effects of power disturbances and guard the integrity of your equipment. The Powerware 5115's flexibility to handle an array of network devices makes it the perfect choice to protect your LANs, servers, workstations, and other electrical equipment.

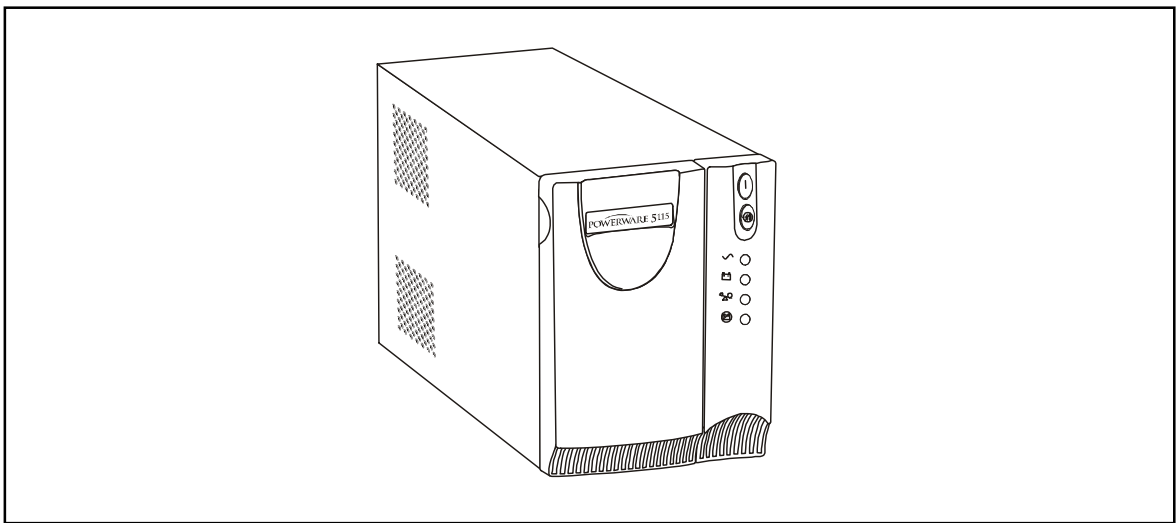

Figure 1. Powerware 5115

Because an integral part of power protection is power management software, the Powerware 5115 comes fully equipped with a communication port, serial cable, and a CD containing both LanSafe III for networked systems and FailSafe III for standalone systems.

Providing outstanding performance and reliability, the Powerware 5115's unique benefits include the following:

- Advanced Battery Management (ABM™) doubles battery service life, optimizes recharge time, and provides advanced warning before the end of battery life.
- Buck and Boost voltage regulation ensures consistent voltage to your load by correcting voltage fluctuations.
- Hot-swappable batteries simplify maintenance by allowing you to replace batteries safely without powering down the critical load.
- Network Transient Protector guards your network equipment from surges.
- Start-on-battery capability allows you to power up the UPS even if utility power is not available.
- The Powerware 5115 is backed by worldwide agency approvals.

Special Symbols

The following are examples of symbols used on the UPS to alert you to important information:



RISK OF ELECTRIC SHOCK - Indicates that a risk of electric shock is present and the associated warning should be observed.



CAUTION: REFER TO OPERATOR'S MANUAL - Refer to your operator's manual for additional information, such as important operating and maintenance instructions.



SAFETY EARTHING TERMINAL - Indicates the primary safety ground.



LOAD ON/OFF - Press the button with this symbol to energize the output receptacles (⌚ indicator illuminates) or to de-energize the output receptacles (⌚ indicator is off).

RJ-45 RECEPTACLE - This receptacle provides network interface connections. Do not plug telephone or telecommunications equipment into this receptacle.



This symbol indicates that you should not discard the UPS or the UPS batteries in the trash. The UPS may contain sealed, lead-acid batteries. Batteries must be recycled.

2. Installation

Inspecting the Equipment

If any equipment has been damaged during shipment, keep the shipping cartons and packing materials for the carrier or place of purchase and file a claim for shipping damage. If you discover damage after acceptance, file a claim for concealed damage.

To file a claim for shipping damage or concealed damage: 1) File with the carrier within 15 days of receipt of the equipment; 2) Send a copy of the damage claim within 15 days to your service representative.

Safety Precautions

Read the following precautions before you install the UPS.

SAVE THESE INSTRUCTIONS. This manual contains important instructions that you should follow during installation and maintenance of the UPS and batteries.

Please read all instructions before operating the equipment and save this manual for future reference.



WARNING

This UPS contains its own energy source (batteries). The output receptacles may carry live voltage even when the UPS is not connected to an AC supply.

Do not remove or unplug the input cord when the UPS is turned on. This removes the safety ground from the UPS and the equipment connected to the UPS.

To reduce the risk of fire or electric shock, install this UPS in a temperature and humidity controlled, indoor environment, free of conductive contaminants. Ambient temperature must not exceed 40°C (104°F). Do not operate near water or excessive humidity (95% max).

To comply with international standards, the sum of earth leakage current from the load connected to the UPS must not exceed 1.5 mA.

Installing the UPS

The following steps explain how to install the UPS. See “UPS Rear Panels” on page 9 for the rear panel of each model.

Please see a typical installation (fig 2)

1. If you are installing power management software, connect your computer to the USB port or UPS communication port using the supplied cable(see page12 and 13).



NOTE

If you need to change the factory-set defaults for the output voltage or input voltage range, see “Voltage Configuration” on page 11 before installing the UPS.

2. Unplug the power cord from your largest load. Plug this power cord into the male inlet of your UPS. You do not need to remove the cord from the wall outlet.

3. Plug the equipment to be protected into the UPS output receptacles.

DO NOT protect laser printers with the UPS because of the exceptionally high power requirements of the heating elements.

4. Start the UPS by pressing the  button. The  indicator illuminates indicating that power is available from the UPS output receptacles.

The UPS conducts a self-test and enters Normal mode. If the alarm beeps or a UPS alarm indicator stays on, see Table 3 on page 16.

The installation is complete. To learn how to operate the UPS, see “Operation” on page 10.

NOTE

The batteries charge to 90% capacity in approximately 3 hours. However, it is recommended that the batteries charge for 6 to 24 hours after installation or long-term storage.

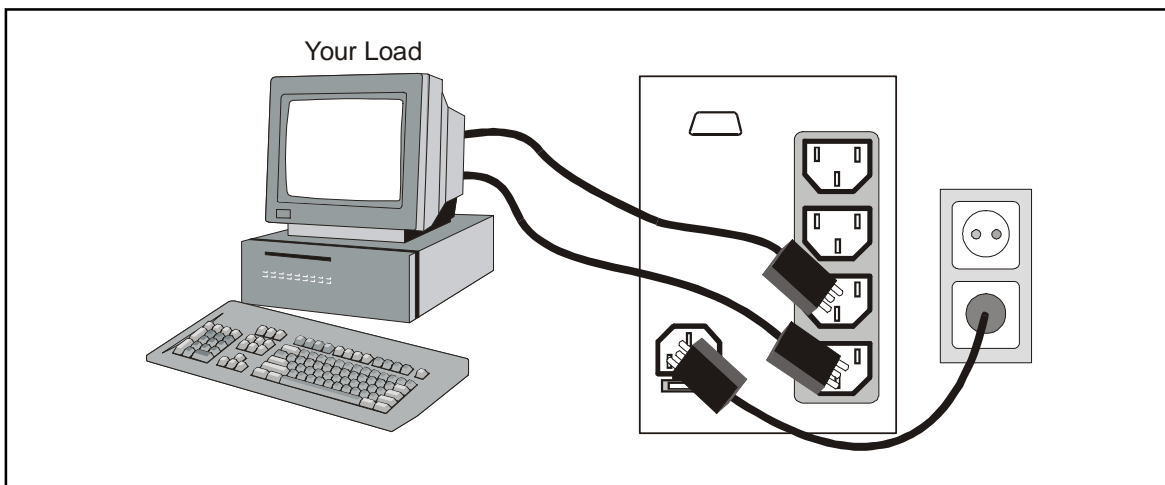

Figure 2. Installation

UPS Rear Panels

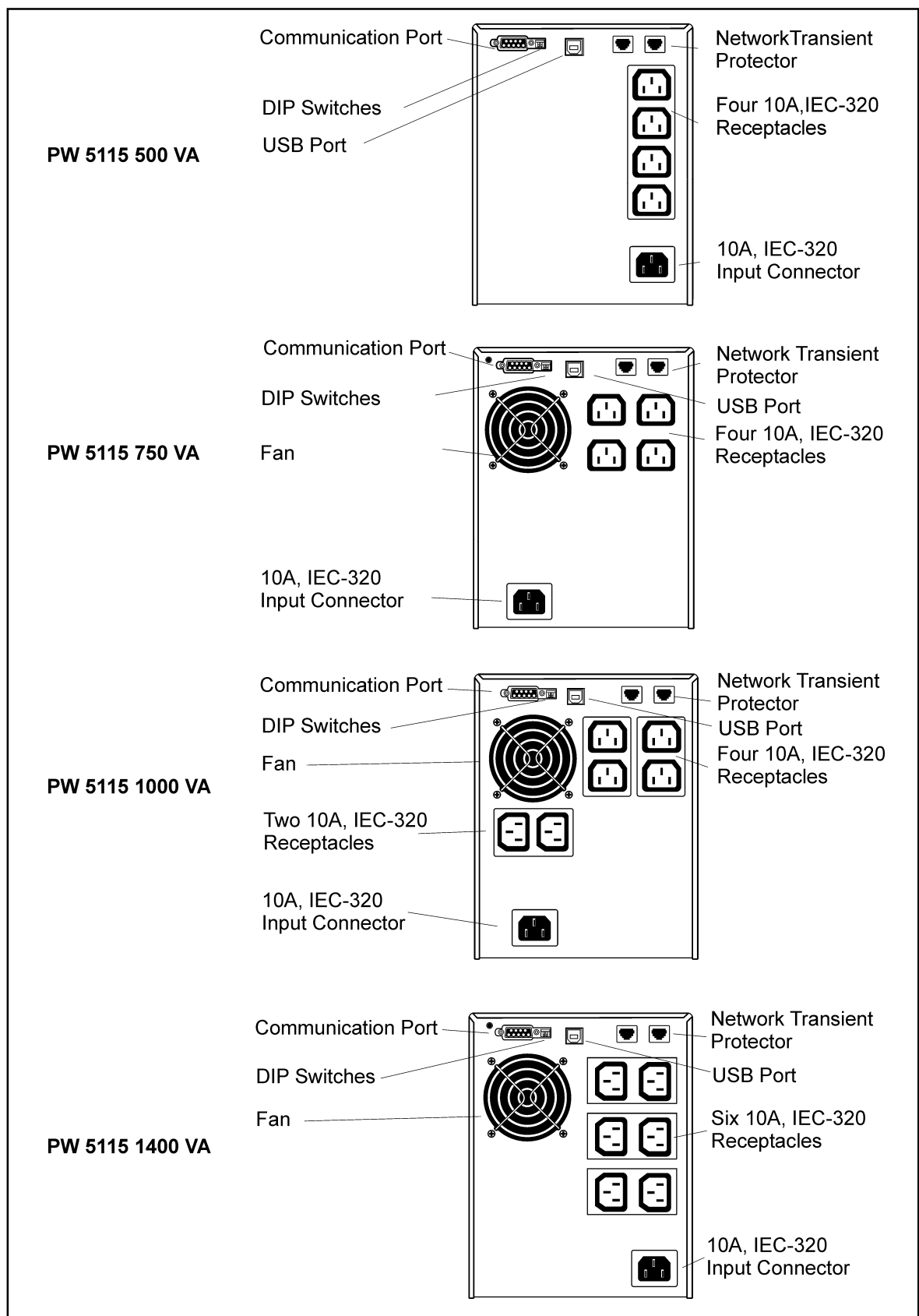





Figure 3. Rear panels

3. Operation and Configuration

Turning the UPS On

To turn on the UPS, press the  button on the front panel (shown in Figure 4). After the UPS is turned on, it conducts a self-test and enters Normal mode. The  indicator illuminates indicating that power is available from the UPS output receptacles.

Starting the UPS on Battery

To turn on the UPS without using utility power, press and hold the  button for two seconds. When the UPS starts on battery, it does not conduct a self-test to conserve battery power.

NOTE

The UPS does not automatically detect the input frequency when starting on battery. The default frequency for 230V models is 50 Hz;

Turning the UPS Off

To turn off the UPS, press the  button on the front panel and then unplug the UPS from the power outlet. If you do not unplug the UPS, it remains in Standby mode.

Standby Mode

When the UPS is turned off and plugged into a power outlet, the UPS is in Standby mode. The battery recharges when necessary and the  indicator is off, indicating that power is not available from the UPS output receptacles.

UPS Front Panel

The UPS front panel indicates the UPS status and also identifies potential power problems. Figure 4 shows the UPS front panel indicators and controls. If the alarm beeps or any alarm indicators are on, see Table 3 on page 17 to identify and correct the problem.

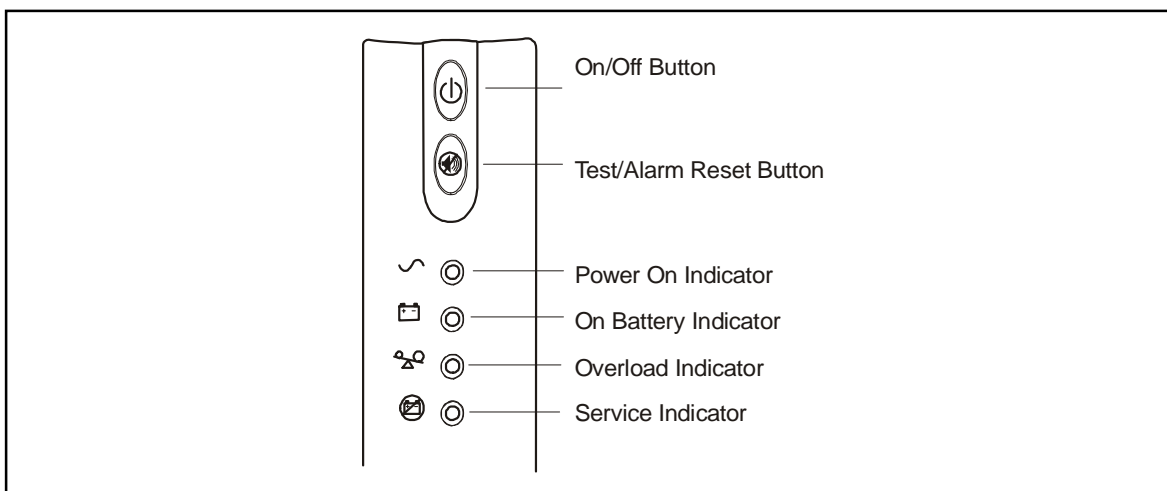



Figure 4. UPS Front Panel

Initiating the Self-Test



Press and hold the  button for three seconds to initiate the self-test. If the UPS finds a problem, an LED indicates where the problem is. For more information, see “Troubleshooting” on page 17.

NOTE

The UPS must not be in Battery mode to perform the self-test.

Voltage Configuration

The DIP switches on the rear panel of each unit (see Figure 5) are used to configure the output voltage and input voltage range.

1. The UPS must be completely shutdown.
Turn the UPS off by pressing the  button on the front panel and then unplug the UPS.
2. Set the DIP switches according to the configurations in Table 1.
3. Plug the UPS into a power outlet and press the  button to turn the UPS on.

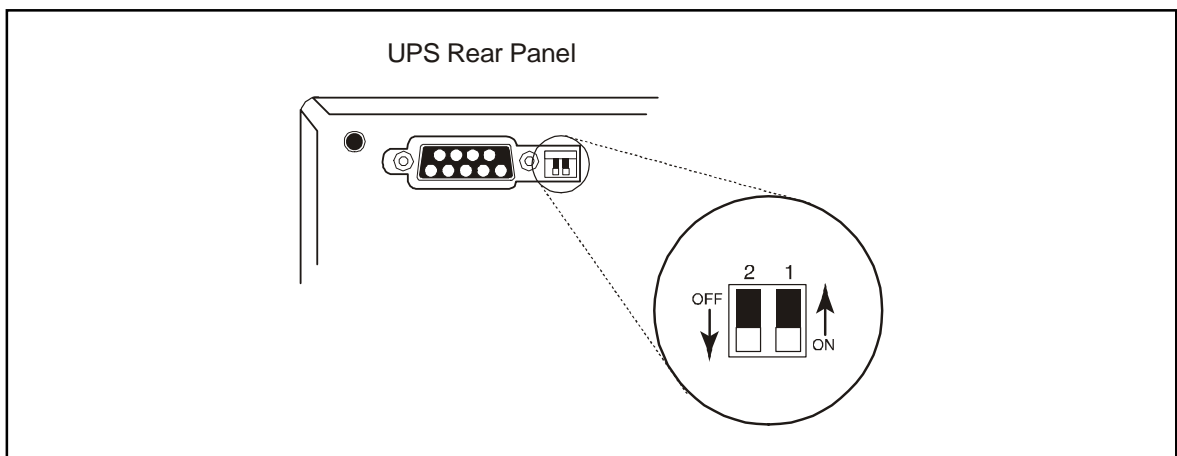

Figure 5. DIP Switches

Output Voltage	Input Voltage Range	DIP Switch 1	DIP Switch 2
220 V	198 V - 233 V	ON	OFF
230 V*	207 V - 243 V*	OFF	OFF/ON
240 V	216 V - 254 V	ON	ON

*Default position

Table 1. DIP Switch Settings

4. Communication Options

The UPS is equipped with a USB and a DB-9 communication port. Either the USB port or the DB-9 communication port may be used to monitor the UPS; however, they cannot operate simultaneously.

Communication Port

To establish communication between the UPS and a computer, connect your computer to the UPS communication port using the supplied communication cable.

When the communication cable is installed, power management software can exchange data with the UPS. The software polls the UPS for detailed information on the status of the power environment. If a power emergency occurs, the software initiates the saving of all data and an orderly shutdown of the equipment.

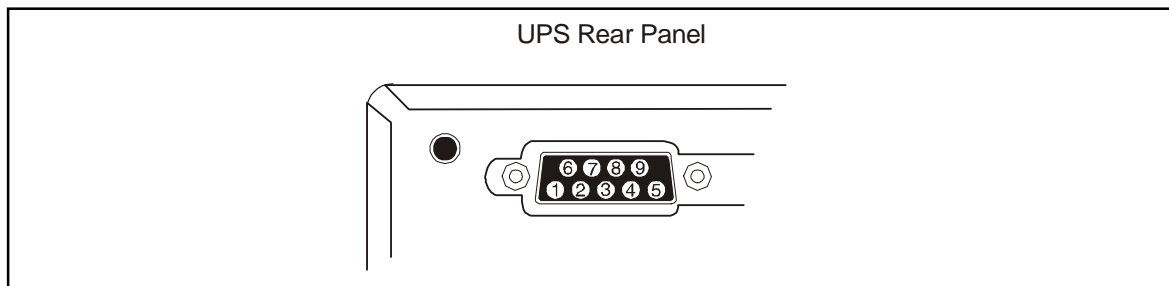

Figure 6. Communication Port

Pin Number	Signal Name	Function
1	DCD	Low Battery relay contact; 20 mA, 30 Vdc contact rating
2	RxD	Receive from external device
3	TxD	Transmit to external device
4	DTR	PnP (Plug and Play) from external device (tied to Pin 6)
5	GND	Signal common (tied to chassis)
6	DSR	Tied to Pin 4
7	RTS	No Connection
8	CTS	AC Fail relay contact; 20 mA, 30 Vdc contact rating
9	RI	+V (8 to 24 volts DC power)

Table 2. Communication Port Pin Assignment

USB Port

The UPS can communicate with a USB-compliant computer using LanSafe Power Management Software (v4.15 or higher). To establish communication between the UPS and a computer:

1. Connect the USB cable to the USB port on the UPS rear panel.
Connect the other end of the USB cable to the USB port on your computer.

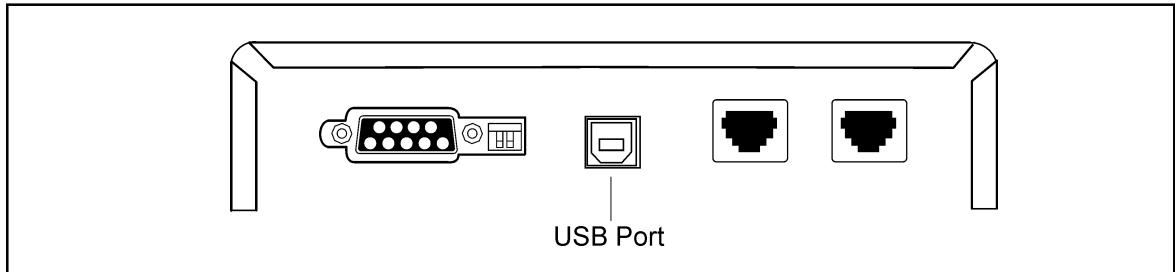

Figure 7. The USB Port

2. Install the LanSafe software and USB drivers according to the instructions provided with the Powerware Software Suite CD.

Network Transient Protector

The Network Transient Protector, shown in Figure 8, is located on the rear panel and has jacks labeled IN and OUT. This feature accommodates a single RJ-45 (10BaseT) network connector.

Connect the input connector of the equipment you are protecting to the jack labeled IN. Connect the output connector to the jack labeled OUT.

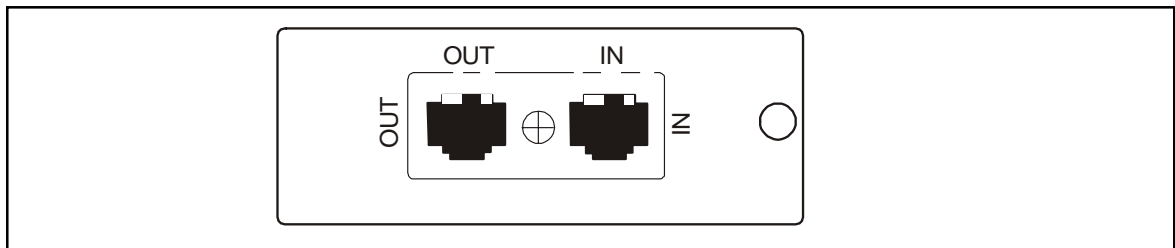

Figure 8. Network Transient Protector

5. UPS Maintenance

UPS and Battery Care

For the best preventive maintenance, keep the area around the UPS clean and dust-free. If the atmosphere is very dusty, clean the outside of the system with a vacuum cleaner. For full battery life, keep the UPS at an ambient temperature of 25°C.

Storing the UPS and Batteries

If you store the UPS for a long period, recharge the battery every 6 months by plugging the UPS into a power outlet. The batteries charge to 90% capacity in approximately 3 hours. However, it is recommended that the batteries charge for 6 to 24 hours after long-term storage.

Replacing Batteries

The hot-swappable battery feature allows you to replace the UPS batteries easily without turning the UPS off or disconnecting the load.

If you prefer to remove input power to change the battery, press the ⏻ button and then unplug the UPS.

Consider all warnings, cautions, and notes before replacing batteries.



WARNING

Batteries can present a risk of electrical shock or burn from high short circuit current. The following precautions should be observed: 1) Remove watches, rings, or other metal objects; 2) Use tools with insulated handles; 3) Do not lay tools or metal parts on top of batteries.

ELECTRIC ENERGY HAZARD. Do not attempt to alter any battery wiring or connectors. Attempting to alter wiring can cause injury.

The battery is not isolated from AC input. Hazardous voltage may exist between battery terminals.

Replace batteries with the same number and type of batteries as originally installed in the UPS.

DO NOT DISCONNECT the batteries while the UPS is in Battery mode.



CAUTION

Pull the battery out onto a flat, stable surface. The battery is unsupported when you pull it out of the UPS.



Use the following steps to replace the batteries:

1. Pull the top left corner forward and remove the front panel.
2. Slide up and remove the metal battery cover.
3. **500 unit.** Disconnect the red battery cable and then disconnect the black battery cable. Pull the battery out onto a flat, stable surface.
4. **750 - 1400 VA units.** Disconnect the red battery cable and then pull the battery out onto a flat, stable surface. Disconnect the black battery cable to the UPS as shown.
5. Replace the battery. See “Recycling the Used Battery” for proper disposal.
6. Connect the black battery cable to the new battery and then connect the red battery cable.
7. Reinstall the battery.
8. Reinstall the metal battery cover and front panel.

Testing New Batteries

NOTE

It is recommended that the batteries charge for 6 to 24 hours before testing.

Press and hold the  button for three seconds to initiate a self-test. The UPS automatically distributes the load to the batteries for 15 seconds and tests the battery's performance. If there is a problem with the battery, the alarm beeps, the  indicator illuminates and the  indicator flashes. Check the battery connections and be sure the battery is fully charged.

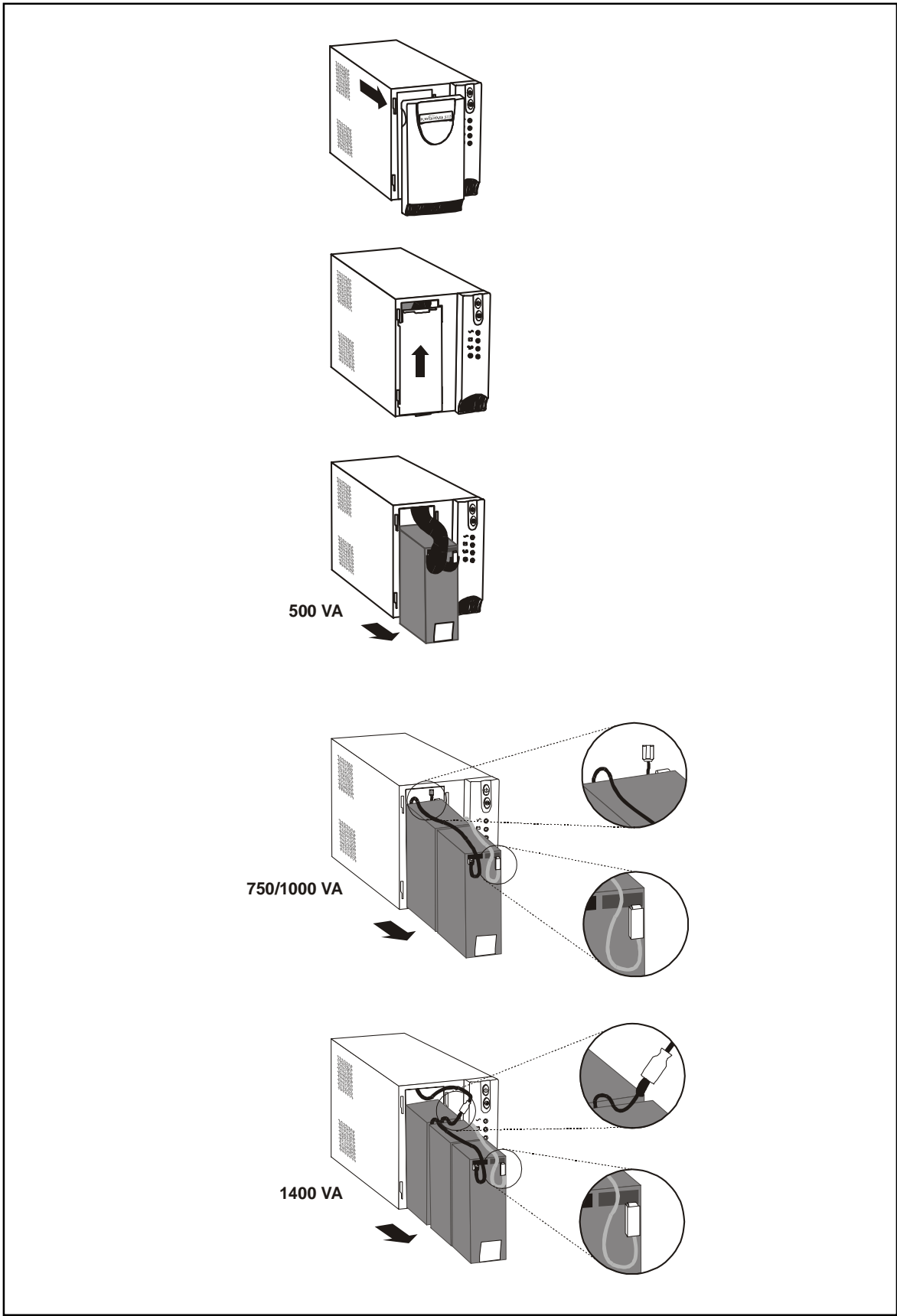

Fig. 9 Swapping batteries



Recycling the Used Battery

Contact your local recycling or hazardous waste center for information on proper disposal of the used battery.

Scrapping the UPS

Before scrapping UPS battery bank must be removed.

Local requirements must be followed in battery recycling or discard.

	WARNING!	
HAZARDOUS MATERIALS. Batteries may contain HIGH VOLTAGES, and CAUSTIC, TOXIC and FLAMMABLE substances. Batteries can injure or kill people and damage equipment if used improperly. DO NOT DISCARD unwanted batteries or battery material in the public waste disposal system. Follow ALL applicable, local regulations for storage, handling and disposal of batteries and battery materials.		



6. Troubleshooting

Audible Alarms and UPS Conditions

The UPS has an audible alarm feature to alert you of potential power problems. When the alarm is activated, the UPS beeps in different intervals according to a particular condition. Use Table 3 to determine and resolve the UPS alarms and conditions.

Silencing an Audible Alarm

To silence the alarm for an existing fault, press the  button. If UPS status changes, the alarm beeps, overriding the previous alarm silencing. The alarm does not silence if there is a UPS fault, low battery condition, or if the battery needs to be replaced.

Alarm or Condition	Possible Cause	Action
The  indicator is not on; the UPS does not start.	The power cord is not connected	Check the power cord connections.
	The wall outlet is faulty.	Have a qualified electrician test and repair the outlet.
UPS does not provide the expected backup time.	The battery may be fully discharged because of: ong-term storage frequent power outages end of battery life	Plug the UPS into a power outlet for 24 hours to charge the battery. Press the  button, if the alarm beeps, see "Replacing Batteries" to replace the battery. During extended power outages, turn off the UPS after saving your work and shutting down your computer to conserve battery charge.











































Alarm or Condition	Possible Cause	Action
 ●	Normal operation.	None. The UPS is operating in Normal mode and automatically provides consistent voltage with the Buck and Boost feature.
 ● 1 beep every 4 seconds.	Utility power failure.	The UPS is powering your equipment with its internal battery. If this is an extended power outage, save your work and turn off your equipment to conserve battery power.
  1 beep every 2 seconds.	The battery is running low.	2 minutes or less of battery power remains (depending on load and battery charge). Prepare for a shutdown. Save your work and turn off your equipment. The alarm cannot be silenced.
 ● 1 beep every 2 seconds.  ●	The UPS is running on battery power because the input voltage is too high or too low.	Correct the input voltage, if possible. The UPS continues to operate on battery until the condition is corrected or the battery is completely discharged. If the condition persists, the input voltage in your area may differ from the UPS nominal. Change the UPS input voltage to match your local voltage (see "Voltage Configuration").
 ● 1 beep per second.  ●	Power requirements exceed UPS capacity (overload is greater than 120%) or the load is defective.	The UPS will automatically shut down in three minutes. Save your work immediately and turn off your equipment. Turn off the UPS. Remove some of the equipment from the UPS. You may need to obtain a larger capacity UPS.
 ● 1 beep per second.  ●	The UPS is on battery, and the power requirements exceed UPS capacity (overload is greater than 120%) or the load is defective.	Shutdown is imminent (30 seconds). Save your work and turn off your equipment. Turn off the UPS. Remove some of the equipment from the UPS. You may need to obtain a larger capacity UPS.
 ● Continuous beep.  	Battery test failed.	Check the battery connections and be sure the battery is fully charged. If the  indicators still flashes, see "UPS Maintenance" to replace the battery. Call your service representative if the problem persists.
 ● Continuous beep.  ●  	UPS internal temperature is too high.	Shutdown is imminent. Save your work and turn off your equipment. Turn off the UPS. Clear vents and remove any heat sources. Ensure the airflow around the UPS is not restricted. Wait at least 5 minutes and restart the UPS. If the condition persists, contact your service representative.
 ● Continuous beep.  	UPS fan fault. 750 - 1400 VA	Save your work and turn off your equipment. Turn off the UPS. Contact your service representative.
  3 beeps every 10 seconds.      	Failed attempt to start the UPS on battery.	Plug the UPS into a power outlet for 24 hours to charge the battery. After charging the battery, press and hold the  button for 3 seconds; then check the  indicator. If the  indicator still flashes, see "UPS Maintenance" to replace the battery.
  Continuous beep.    	The output wave is abnormal while the UPS is on battery.	Shutdown is imminent. Save your work and turn off your equipment. Turn off the UPS. Contact your service representative.
  Continuous beep.  	The output voltage is below or above the limit while the UPS is on battery.	Save your work and turn off your equipment. Turn off the UPS. Contact your service representative.

Table 3. Troubleshooting

Service and Support

If you have any questions or problems with the UPS, call your **Local Distributor**.

Warranty

The product is warranted against defects in material and workmanship for a period of 24 months from its original date of purchase.

7. Specifications

General

UPS Models	PW5115 500i PW5115 750i PW5115 1000i PW5115 1400i
------------	--

Input

Nominal Voltage	220,230,240 Vac, selectable
Voltage range	+/- 20% for nominal voltage at full load
Nominal Frequency	45-65 Hz, 50/60 Hz auto-sensing
Efficiency, Normal mode	95%
Noise filtering	Full-time EMI/RFI filtering
Overcurrent protection	Resettable input overcurrent protector
Connections	10A, IEC-320 input connector

Output

Power levels (rated at nominal inputs)	500VA, 320W 750VA, 500W 1000VA, 670W 1400VA, 950W
Regulation (Normal mode)	-10% to +6% of nominal voltage
Regulation (Battery mode)	+/-5% of nominal
Voltage Waveform	Sine wave
Overcurrent protection	Inverter saturation, current limited

Battery

Configuration	500VA, (1) 12V, 9 Ah internal battery 750VA, (2) 12V, 7 Ah internal battery 1000VA, (2) 12V, 9 Ah internal battery 1400VA, (3) 12V, 9 Ah internal battery
Type	Seales, maintenance-free, valve-regulated, lead acid
Recharge time	<3 hours to 90% usable capacity
Monitoring	Advanced monitoring for earlier failure detection and warning
Backup time (typical full load)	5 min

Environmental

Operating Temperature	Up to 1500 m 0° C to + 40° C Above 1500 m 0° C to + 35° C
Transit/Storage Temperature	-15° C to + 55° C
Relative Humidity	5-95% noncondensing
Operating Altitude	Up to 3000 meters above sea level
Audible noise	Less than 45 dBA typical

Safety and markings

Surge Supression	ANSI C62.41 category A
Safety Conformance	EN 50091-1-1 and IEC 60950 UL1778, UL 497 (data line only) CAN/CSA C22.2 No. 107.1
EMC (Class B)	EN 50091-2, FCC Part 15, ICES-003
Markings	CE, TUV, UL, cUL, C-Tick

Dimensions and weights

	500 VA	750 VA	1000 VA	1500 VA
UPS Dimensions (WxDxH mm)	150x268x185mm	150x333x185mm	150x333x185mm	150x388x185mm
UPS Weight (kg)	8 kg	12 kg	13 kg	17 kg

Battery runtime chart

UPS Models by VA ratings				
Load (VA)	500	750	1000	1400
200	17	38	41	58
300	11	27	28	41
500	5	14	15	28
600		9	10	19
750		6	8	14
900			6	10
1000			5	8
1200				6
1400				5

NOTE Battery times are approximate and vary depending on the load configuration and battery charge.