

Powerware series

Eaton 9395 UPS  
225 - 1100 kVA

Unmatched  
green power

**EATON**

*Powering Business Worldwide*

# Introduction and overview

As IT managers, facility managers and CIOs face increasing pressure to achieve zero downtime, reduce energy costs by scaling down data centres and meet sustainability requirements, the quest for the most reliable and efficient power protection system has become more critical. With an unprecedented level of power performance, reliability and energy savings, Eaton® has raised the bar in three-phase power protection technology with the Eaton 9395 UPS, the state-of-the-art product from the Powerware® series.

## Key applications

- Large data centres
- Server farms
- Telecommunication installations
- Internet service providers
- Transportation systems
- Security operations
- Broadcasting and entertainment
- Process control equipment
- Financial systems
- Credit card operations
- Industrial systems
- Healthcare
- Multiple medical imaging units

**The 9395 delivers a wide scope of superior customer-driven benefits:**

### Premium power performance and true reliability

- Enhanced power protection due to double-conversion design and lower ITHD
- Dependable operations with Powerware Hot Sync® paralleling technology
- Option to build parallel systems either with distributed or centralised static bypass switch
- Increased reliability through inherent redundancy and Intelligent Power® software
- Longer battery runtimes due to higher efficiency and ABM® technology
- Higher availability through concurrent maintenance

### Lower TCO through sustainable design

- Savings on source materials, space and freight costs due to reduced footprint and weight
- Reduction in energy consumption during manufacturing, testing and use
- Electrical and cooling cost savings due to higher up to 99 per cent efficiency with EAA technologies
- Flexible, upgradeable architecture for future expansion needs
- Longer component life due to higher efficiency
- Installation and testing savings with the Easy Capacity Test
- Reduced end-of-life impact because the materials are recyclable

### Tailor-made solutions

- Customised solutions for different markets and customers



# Premium power performance and true reliability

## Double-conversion design for highest power protection

Eaton's double-conversion design outperforms the competitors by completely isolating output from input power anomalies, while regulating both voltage and frequency to deliver 100 per cent conditioned, perfect sine wave output. Even under the most severe power disturbances, power output remains stable with the Eaton 9395 UPS.

## Enhanced power performance

Power performance is measured by system efficiency, ITHD, and input and output power factor. A robust combination of these elements makes the Eaton 9395 the premier UPS in its class.

The 9395 delivers an efficiency of up to 94.5 per cent. This high level of performance is powered by modern transformer-free technology with small, lightweight filter inductors, high performance IGBTs in the rectifier and inverter, and an advanced control algorithm. The graph on the right shows how efficiency generally dips as load level decreases. In general, manufacturers list an optimal efficiency rating at full load. In reality, however, most three-phase UPSs operate in the range of 30 – 50 per cent load. The 9395 can provide exceptional efficiency at half load capacity.

Additionally, because of IGBT technology, the 9395 does not require input filters to obtain excellent input ITHD, unlike most other manufacturers, whose UPSs require input filters that ultimately lower their efficiency rating. Due to low input ITHD (less than 3 – 5 per cent) and high input power factor (over 0.99), the 9395 is exceptionally compatible with diverse power sources, especially generators, but is also mains friendly due to its low harmonic content.

On the output side, the 9395 supports leading power factor loads, which are becoming more prevalent in new and updated data centres, thus delivers its full power capability. The 9395 handles, without derating, down to 0.8, which is the leading power factor of modern computer and server loads.

These technological innovations result in dramatic cost savings, given extended battery runtime, longer life of components and cooler operating conditions within the UPS.

The table on the right shows how the 9395 compares with competing UPS models in terms of efficiency and resulting cost savings.

Efficiency vs. Load

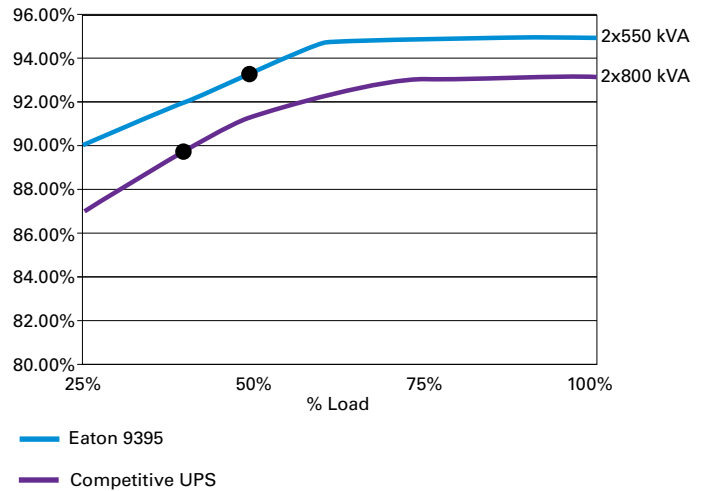

## Savings achieved with Eaton 9395 550 kVA

Load rating (VA) =	550 000
Load Power Factor =	0,9
Unit Watts =	495 000
Energy cost per kWh* =	0,09 euro
Competitive product efficiency from graph =	90.5%
9395 UPS efficiency from graph =	94.0%
Loss in Watts with competitive product =	51 961
Loss in Watts with 9395 UPS =	31 595
Extra energy used to operate competitive product =	20 365
Loss in BTU/hr with competitive product =	177 299
Loss in BTU/hr with 9395 UPS =	107 809
Extra BTU/hr used to operate competitive product =	69 490
Daily energy savings using 9395 UPS =	44,97 EUR/day
Yearly energy savings using 9395 UPS =	16 413 EUR/year
Cooling efficiency ratio =	70%
Daily cooling savings using 9395 UPS =	31,48 EUR/day
Yearly cooling savings using 9395 UPS =	11 489 EUR/year
<b>Total yearly combined savings per 9395-550 kVA =</b>	<b>27 902 EUR</b>
Quantity of Modules =	4
<b>Total yearly savings using 9395-550 kVA =</b>	<b>111 608 EUR</b>

\* average energy cost per kWh in EMEA (usage charge + taxes)

**Unique modular design offers capacity and redundancy**

Eaton 9395 UPS has an innovative modular design, containing up to four uninterruptible power modules (UPM), each of them rated for a maximum of 275 kVA.

This built-in modularity makes it possible to provide customers with a single UPS solution rated from 275 up to 1100 kVA, or with a redundant solution when UPMs inside the cabinet are configured to operate as redundant modules at lighter loads. Anytime the load is N-1 (where N is a number of 275kVA UPMs), the UPS

system automatically becomes redundant. This might be the single most important feature that saves customers from dropping their load. Other UPS manufacturers can not deliver this possibility without adding a more costly second UPS module.

Furthermore, the 9395 UPS is adaptable for future changes in load demands and new requirements for higher reliability – a 275kVA UPM can be added in the field for N+1 redundancy or capacity (depending on the static switch rating).

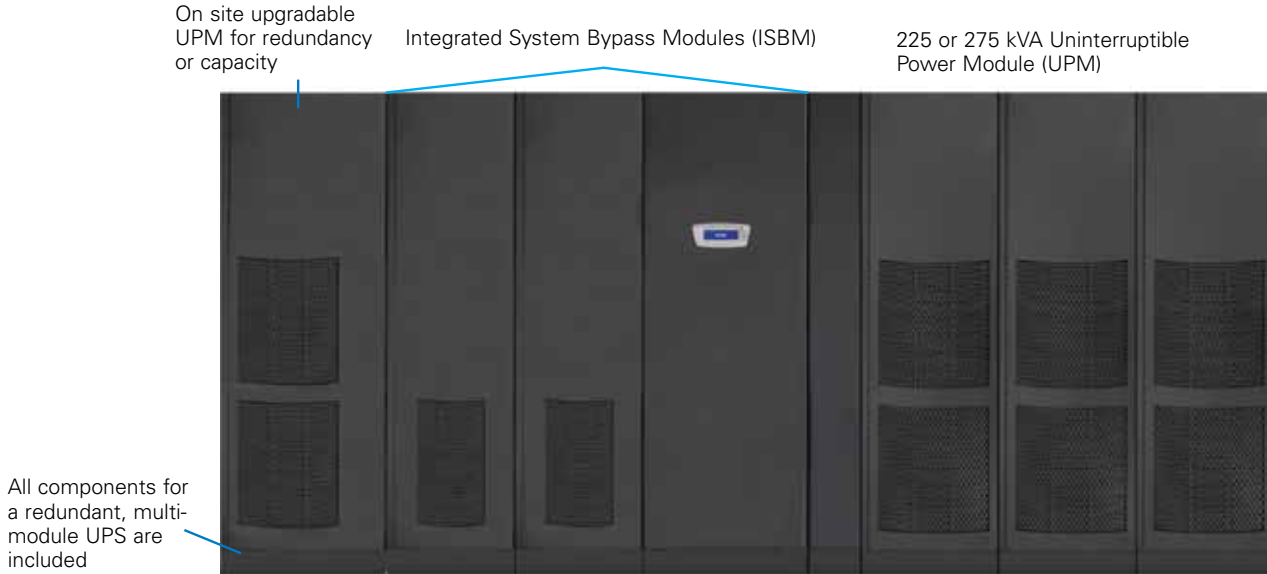

**Eaton 9395 825 kVA N+1 or 1100 kVA capacity**

**Powerware Hot Sync technology boosts system reliability**

The number one function of a UPS is to supply continuously conditioned, reliable electricity for a critical load. With Eaton’s patented Powerware HotSync parallel load-sharing technology absolute reliability can be achieved.

HotSync enables a multi-module configuration to operate in parallel without the need for inter-module communications. This eliminates the system level single-point-of-failure and maximises availability.

**Hot Sync redundant** allows N+x parallel installation of UPSs, with the UPS modules sharing the critical load between them.

Should a failure of any kind occur with either module, the critical load remains 100% UPS protected. Internal diagnostics immediately isolate the faulty UPS module from the critical bus while the other UPS assumes the full load.

**Hot Sync capacity** enables UPS modules to operate in parallel to increase the load capacity. By adding more UPS modules than is needed to support the load, redundancy can also be achieved.

HotSync technology is employed when paralleling UPMs inside a single UPS to create inherent redundancy, as well as when paralleling separate UPSs as a part of a larger system.

**Key design features of Hot Sync systems**

- No system-level single point of failure
- Paralleled UPMs/UPSs operate independently. One module cannot affect or interfere with the others – no domino effect scenario
- No added circuitry is required for parallel operation. Any standard UPS can be used in a parallel system without modification
- This patented and proven technology has been successfully deployed in thousands of systems around the world

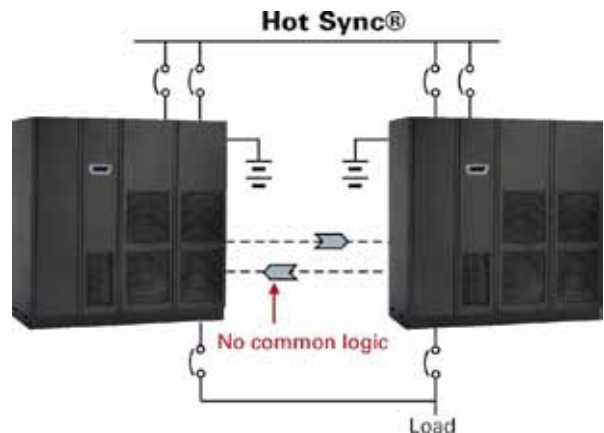

**Patented Hot Sync technology provides highest availability for load**

### Meeting the power quality needs of mega data centres

For customers with massive power supply needs, Eaton offers a choice between two technical solutions for paralleling 9395 systems to best match their power quality requirements:

- 1) Distributed bypass – where every UPS unit in the system has an individually controlled Integrated System Bypass Module (ISBM).
- 2) Centralised bypass – where all UPS units use a common system-rated, high-power, static-bypass switch.

Both solutions allow the use of Eaton’s technologies Energy Saver System (ESS) and Variable Module Management System (VMMS) for enhanced efficiency and substantial energy savings.

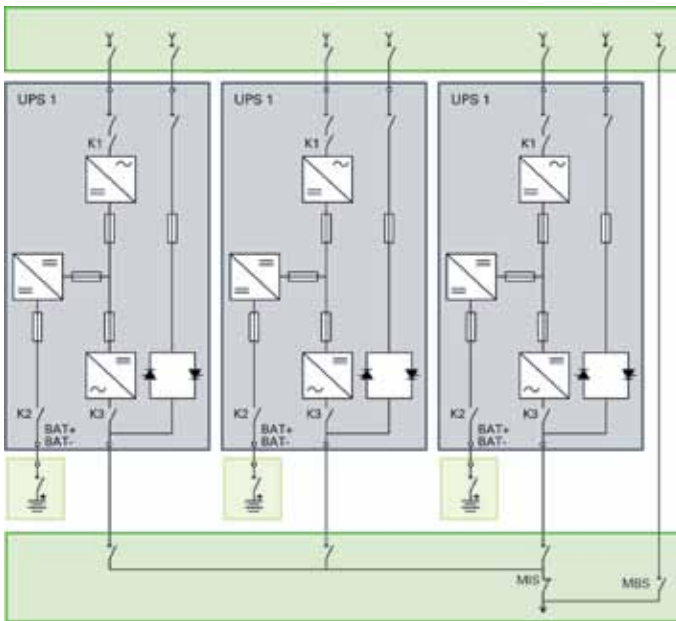

**Parallel system with a distributed bypass**

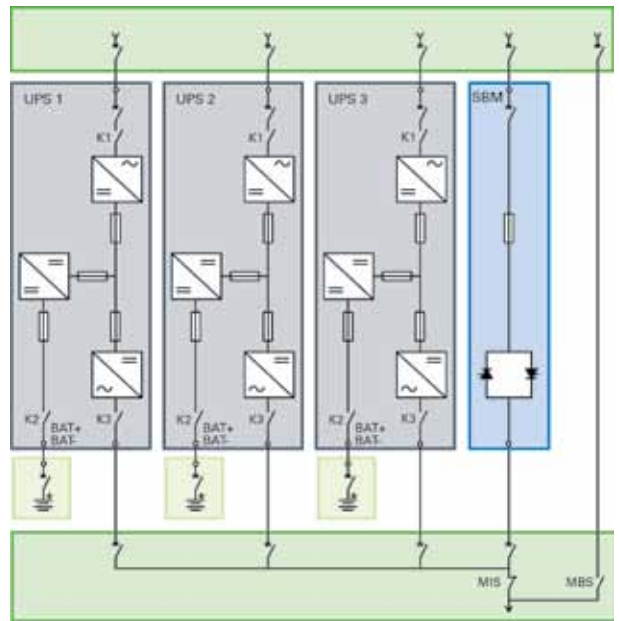

**Parallel system with a centralised bypass**

### Building a centralised bypass solution with Eaton 9395 SBM

An Eaton 9395 SBM is built to deliver custom, multi-module UPS configurations with a centralised bypass. The SBM can be used with UPS systems from 2,000 amperes up to 5,000 amperes (1.4 – 3.5 MVA) and is capable of paralleling UPS units with unequal kVA ratings – for example, one 550 kVA unit and one 275 kVA unit, or three 825 kVA units with one 550 kVA unit.

### Sync Control

Sync Control ensures that the output of two or more separate UPSs (single modules or parallel systems) remain in phase with each other, so that the static transfer switches connecting separate distribution paths may seamlessly change state when necessary.



**The 9395 SBM cabinet**

# Sustainable design lowers total cost of ownership

Due to its outstanding environmental performance, the Eaton 9395 UPS has been awarded the "An Eaton Green Solution™" label. Eaton uses this label to identify products that offer proven exceptional environmental benefits to its customers.

## Unmatched green power performance

The 9395 can operate at up to 94.5 per cent efficiency in double conversion mode and at 99 per cent in Energy Saver System mode, thus reducing utility costs and extending battery runtimes. Higher system efficiency also results in cooler operating conditions, which in turn reduces air conditioning costs, extends the life of UPS components, and increases overall reliability, availability and performance. The environmental impact of using the 9395 is minimised due to its sustainable design and the resulting cost savings.

## Greatly reduced footprint

Compared to traditional UPS designs, a transformer-free UPS typically weighs 50 per cent less and occupies only 60 per cent of the floorspace. In addition, the transformer-free technology is highly efficient even at half load capacity.

The 9395 fits a redundant design into the same footprint as a traditional, non-redundant UPS. Unlike some larger and heavier systems, the 9395 fits easily through all doors, can be transported on freight elevators, and there is no need to dismantle it to fit it on elevators or through doorways, which can cause significant delays and increase costs. Therefore, the 9395's smaller footprint not only reduces your total cost of ownership, but also minimises the impact on shipping.

## Easy Capacity Test reduces testing time and costs

With the Easy Capacity Test, the 9395 can test its entire power train under full load stress, including the rectifier, inverter, contactors, fuses, power busses, cabling, bypass (static switch), magnetics and filter capacitors – all without an external load being connected.

The net result of this innovative load test is that there are no load banks to rent, no temporary load connections to make and no wasted energy, saving you time and money during startup and commissioning tests.

Eaton field technicians are trained to use this load testing capability during service startup to ensure optimum calibration, maximum efficiency and inherent redundancy.

## Eaton 9395 – An Eaton Green Solution

- Less source materials
- Less energy required during manufacturing and testing
- Smaller footprint
- Less energy needed during use, less electrical and cooling costs
- Reduced end-of-life impact



## An Eaton Green Solution

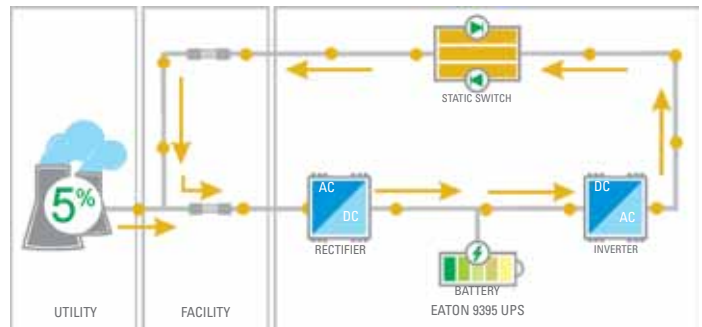

Easy Capacity Test power flow

# Energy Advantage Architecture (EAA)

The Eaton Advantage Architecture (EAA) is an umbrella name for the complementary, innovative energy-saving technologies by Eaton – Energy Saver System (ESS) and Variable Module Management Systems (VMMS) – which offer new ways to maximise UPS energy efficiency without compromising on reliability. These technologies allow engineers and facility managers to get the best possible performance from their UPS while reducing financial and environmental costs.

## Variable Module Management System (VMMS)

Most UPS installations are only loaded between 20-40 per cent, but UPSs are not optimally efficient when used at these lighter loads. As a key component of EAA, the VMMS technology maximises parallel UPS system efficiencies at low load levels while supplying continuous double-conversion power.

VMMS optimally employs uninterruptible power modules (UPMs) in the UPS to achieve higher efficiencies in double-conversion mode. By switching UPMs that are not needed to ready state, the percentage load level of the active UPMs is maximised.

This is calculated according to the VMMS load threshold of the UPMs (80 per cent by default) and the redundancy requirements specified in the system configuration. The result is maximised energy savings.

In the event of an increased load level on a critical bus, all ready-state UPMs are able to revert quickly to double-conversion mode by connecting the existing PWM signals to the IGBT gates.

VMMS is made possible through the Eaton 9395's modular design. It can also be applied in multi-module single-UPS systems.

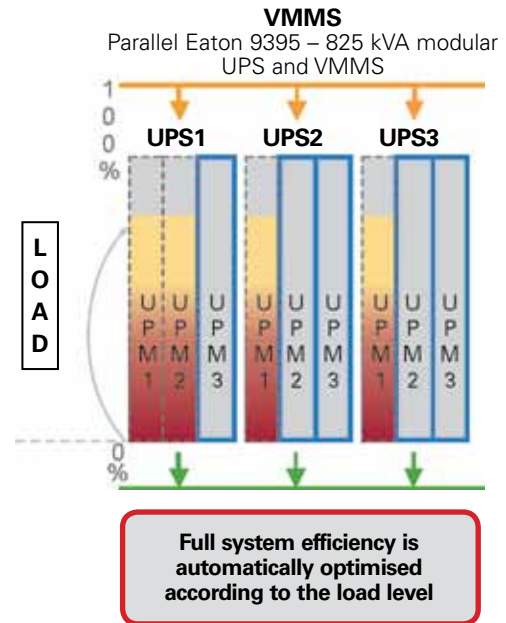

Input power quality within load tolerance



Input power quality within rectifier tolerance



Input power quality out of rectifier tolerance

## Components engaged in different ESS operating modes

## Energy Saver System (ESS)

Energy Saver System technology enables UPS efficiency to reach an impressive 99 per cent. ESS allows the UPS to switch between three configurable operating modes:

- 1) In standard double-conversion mode the UPS operates normally, supplying power through the power converters.
- 2) In Energy Saver System mode the power converters are in ready state and the static bypass switch allows the UPS to supply power from the mains directly. If mains power is lost or exceeds preset output limits, the DC link that is kept active seamlessly switches to double conversion in less than two milliseconds. While in ESS mode, the UPS is also able to detect whether an output fault has been caused by a source or by a load. A fault at the bypass source results in immediate switchover to the inverter, whereas a fault in the load keeps the UPS in Energy Saver System mode.
- 3) In high-alert mode the UPS switches from Energy Saver System to double conversion for one hour. Power quality is constantly controlled during this time. If a high-alert command is received again, for example due to a thunderstorm, the one-hour timer will be reset.

# Ease of maintenance

## Ease to install

The 9395 is a completely integrated, large system that incorporates multiple power modules and system switchgear on factory pre-wired bases. A cabling busbar enters the 9395 UPS from either the top or bottom of the cabinet to making installation easier and more flexible. As everything is pre-wired, the cabling busbar costs and installation time are significantly reduced.

## Concurrent maintenance for higher availability

Eaton field technicians can completely isolate and service a redundant module, without switching to bypass while another module carries the load. The 9395 also features a completely front-accessible design and can be installed against walls or back-to-back in multi-module configuration. This service-friendly design ensures maximum uptime and availability.

## Batteries: the heart of every UPS

When a utility power outage causes a UPS to switch to battery power, it is imperative that those batteries are healthy, charged and up to the task. Improper battery management is the number one cause of downtime. Many UPS batteries on the market today are constantly trickle-charged – a process that degrades the battery's internal chemical composition over time, reducing potential battery life by as much as 50 per cent. To address this, the 9395 uses a sensor and innovative three-stage ABM charging technology to significantly extend battery life and optimise recharging time. In addition, temperature-compensated charging monitors changes in temperature to adjust the rate of charge and prolong battery life.

## Battery monitoring ensures optimal readiness

Advances in firmware and digital technology enable the 9395 to offer sophisticated battery monitoring and management features that you might expect to find only on expensive add-on systems, including:

- Runtime remaining monitor – calculates remaining runtime through system loading and trended battery discharge data, plus internal sensing points for voltage and current data
- Battery circuit test – performs a periodic full-load test of the battery string to ensure that there are no open circuits or weak cells that would jeopardise battery performance and system availability

## Expertise and reliability through Eaton service

Eaton's extended technical support network covers the power protection needs of customers across the EMEA region, with a wide range of service packages available to match different maintenance needs and budgets. Whichever package you choose, you can rest assured that Eaton will deliver power security and reliability to keep your core business running.

Service this module...



Concurrent maintenance in Eaton 9395 550 kVA

...while this module carries the load

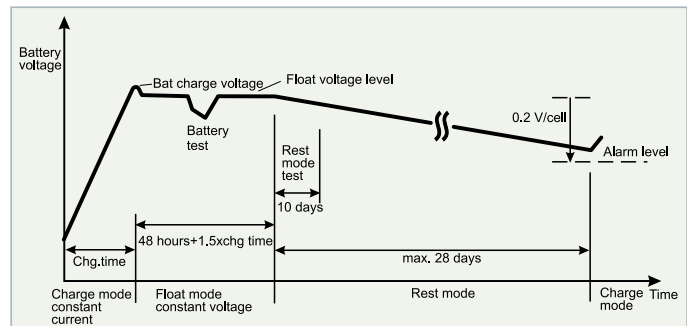

Battery voltage during ABM charging process





# Extensive configurability

## Web card

Eaton 9395 UPS comes equipped with a ConnectUPS Web/SNMP card. This tool is a complete UPS monitoring, control and shutdown solution for a networked IT environment. In case of alert, the Web/SNMP card notifies users and administrators through e-mail. During a prolonged power failure the protected computer systems can also be shut down smoothly with Intelligent Power Protector software.



The ConnectUPS-X Web/SNMP Card allows you to connect your 9395 directly to the ethernet and the internet. This unique solution allows you to conveniently monitor and manage your UPS with a standard Web browser. As an added feature, the unique three-port switching hub on the X-Slot model provides additional network connections.

## Intelligent Power software

Eaton's Intelligent Power Manager (IPM) is a user-friendly monitoring tool for UPSs, ePDUs and environmental sensors. It collects data through the network, storing it in a database to view and analysis later. IPM has a powerful alarm function which collects alarm events from individual devices and sends alerts through e-mail.

Intelligent Power Protector (IPP) performs an orderly and controlled shutdown of powered computers in case a power failure exceeds the battery backup time. IPM can be used to monitor and manage all IPPs running in the network, which dramatically reduces the workload of administrators and minimises the possibility of error.

Intelligent Power software is a welcome addition to today's virtualised data centre. Web-based interfaces simplify usage, allowing access from any computer in the LAN or remotely via the internet. IPM integrates seamlessly with the leading virtualisation management tool, VMware vCenter. It can even trigger vMotion to move virtual machines to other servers or sites if there is a fear of power loss, resulting in zero downtime. IPP supports traditional server operating systems as well as VMware ESX and Microsoft Hyper-V virtual environments.



# Customised solutions

The 9395 is Eaton's answer to customers that need tailor-made solutions for mega data centres requiring high power performance, maximum availability and costs savings. Eaton's project management team, Large Systems Group (LSG), works together with our local sales and project management teams to fulfil customer needs and to meet the sophisticated requirements set by demanding installations, environment and load applications.

For example, UPSs used in marine environments have special dependability requirements due to the harsh environmental conditions they have to withstand and the critical nature of the equipment they protect. Eaton has supplied marine UPSs to hundreds of vessels over the years.

Eaton offers customised 9395-based systems for different markets, including:

- Mega data centres
- Marine and off-shore
- Oil and gas
- Rail and track, underground, traffic, tunnel, mines
- Aviation
- Industrial applications
- Defence/military



# A closer look inside the Eaton 9395

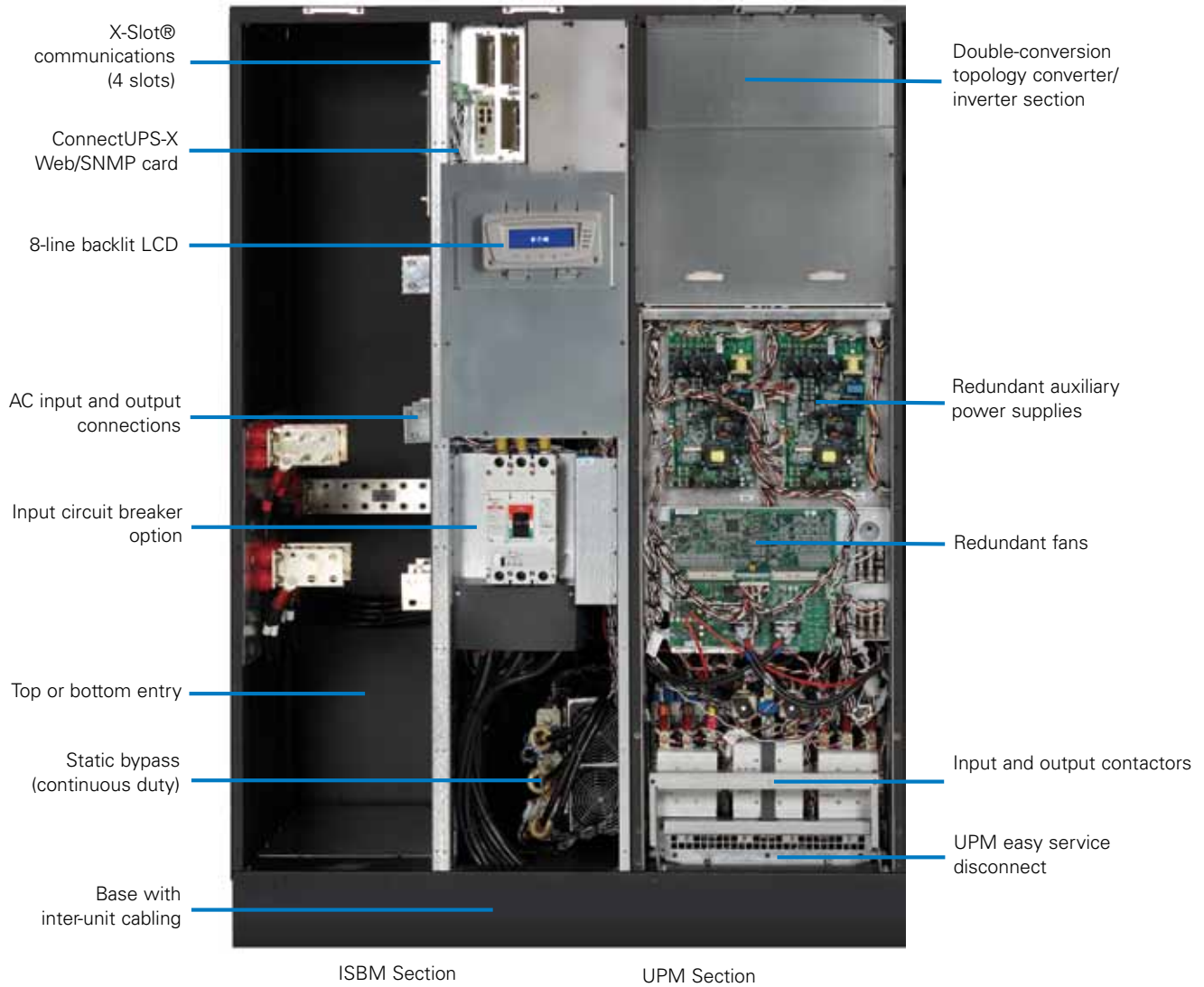

**Eaton 9395 275 kVA**

## TECHNICAL SPECIFICATIONS

### UPS output power rating (0,9 p.f.)

kVA	225	275	450	550	675	825	900	1100
kW	204	250	408	500	612	750	816	1000

### General

Efficiency in double conversion mode (full load)	>94%
Efficiency in double conversion mode (half load)	>93%
VMMS (double conversion)	significantly increased efficiency at low loads
Efficiency in Energy Saver System (ESS)	up to 99%
Distributed parallelling with Hot Sync technology	5 + 1
Internal N+1 redundance capable	in 550 : 275 kVA in 825 : 550 kVA in 1100 : 825 kVA
Field upgradeable	yes
Inverter/rectifier topology	transformer-free IGBT with PWM
Audible noise	<76 dB; <81 dB (825 and 1100 kVA)
Altitude (max)	1000 m without derating (max 2000 m)

### Input

Input wiring	3 ph + N + PE
Nominal voltage rating (configurable)	220/380, 230/400, 240/415 V 50/60 Hz
Input voltage range	+15% / -15%, +10% / -10% for bypass
Input frequency range	45-65 Hz
Input power factor	0,99
Input ITHD	< 3-5% on nominal load, depending on the utility UTHD
Soft start capability	Yes
Internal backfeed protection	Yes, standard

### Output

Output wiring	3 ph + N + PE
Nominal voltage rating (configurable)	220/380, 230/400, 240/415 V 50/60 Hz
Output UTHD	<3% (100% linear load); <5% (reference non linear load)
Output power factor	0,9 (e.g. 250 kW at 275 kVA)
Permitted load power factor	0,7 lagging - 0,8 leading
Overload on inverter	10 min 100-110%; 30 sec 110-125%; 10 sec 125-150%; 300 ms >150%
Overload when bypass available	Continuous <115%, 20 ms 1000% Note! Bypass fuses may limit the overload capability

### Battery

Type	VRLA, AGM, Gel, Wet Cell			
Charging method	ABM technology or Float			
Temperature compensation	with EMP			
Battery nominal voltage (lead-acid)	480 V (40 x 12 V, 240 cells)			
Charging current / Model	275	550	825	1100
Default A	38	76	114	152
Max* A	83	166	249	332

\*Limited by maximum UPS input current rating

### Dimensions and weights

225 kVA, 275 kVA	1350 x 880 x 1880 mm (wxdxh)	830 kg
225, 275 kVA redundant	1890 x 880 x 1880 mm	1430 kg
450, 500, 550 kVA	1890 x 880 x 1880 mm	1430 kg
450, 550 kVA redundant	2630 x 880 x 1880 mm	2030 kg
Field upgrade module, 225 or 275 kVA	740 x 880 x 1880 mm	600 kg
675, 825 kVA	3710 x 880 x 1880 mm	2520 kg
675, 825 kVA + 1 redundant	4450 x 880 x 1880 mm	3120 kg
1100 kVA	4450 x 880 x 1880 mm	3120 kg

### Options – Eaton 9395 SBM

#### 9395 SBM ratings

Model	2000	2500	3200	4000	5000
Rating (A)	2000	2500	3200	4000	5000

### Dimensions and weights

SBM 2000	2200 x 1032 x 1880 mm (wxdxh)	1300 kg
SBM 2500	2200 x 1032 x 1880 mm	1300 kg
SBM 3200	2200 x 1032 x 1880 mm	1450 kg
SBM 4000	2500 x 1032 x 1880 mm	2400 kg
SBM 5000	2500 x 1032 x 1880 mm	2500 kg

### Accessories

External battery cabinets with long-life batteries, X-Slot connectivity (Web/SNMP, ModBus/Jbus, Relay, Hot Sync, ViewUPS-X remote display), integrated manual bypass for 225-550 kVA

### Communications

X-Slot	4 communication bays
Serial ports	1 available
Relay inputs/outputs	5/1 programmable

### Compliance with standards

Safety (CB certified)	IEC 62040-1, IEC 60950-1
EMC	IEC 62040-2
Performance	IEC 62040-3

In the interests of continuous product improvement all specifications are subject to change without notice.

[www.eaton.com/powerquality](http://www.eaton.com/powerquality)

Eaton, Powerware, Hot Sync, Intelligent Power, ABM and An Eaton Green Solutions are trade names, trademarks, and/or service marks of Eaton Corporation or its subsidiaries and affiliates. All other trademarks are the property of their respective owners.



*Powering Business Worldwide*

© 2010 Eaton Corporation  
All Rights Reserved  
Printed in Finland  
00BROC1018090 rev E  
December 2010