

Power Quality Solution for Data Centres

# Eaton BladeUPS

12 - 60 kW

Energy saving efficiency in  
a scalable format



**EATON**

*Powering Business Worldwide*

# High-density computing environments demand more power

Today, the management of a data center or network operations center places you under the intense pressure to reduce costs while dealing with inescapable operational realities:

**Expanding power demands.** The blade servers that are satisfying business demands can raise the demands for power consumption in the same footprint. Rack power requirements that were once at 60 watts per U may now have to be delivered at levels up to 600 watts per U with redundant power supplies.

**Increasing power costs.** Utility rates have a common recurrence, they always go up. Energy costs are emerging as the second highest operating cost (behind labor) in 70% of data centers worldwide. (Gartner, 2009). To this point, many organizations are researching and developing plans to implement efficient and affordable power solutions in their facilities.

**Excessive heat.** Blade servers generate a lot of heat that translates into high demand for additional energy. A fully loaded rack of blade servers can use close to 30 kW of power. This equals over 100,000 BTU/hr in heat generation that requires cooling—wasted heat, which is not utilized in any way. Since cooling adds huge costs to data center operations, IT organizations are forced to increase their power efficiency to counteract the inefficient heat and cooling problems.

If you manage, engineer, or plan the present and future of a data center or network operations center, you are already aware of these critical issues and their impact on operations. Your challenge is to make decisions that provide efficient power protection and distribution for growing loads, while managing the heat.

Eaton® is ready to help you with these challenges.

## Eaton BladeUPS for your data centres

Designed specifically for high density computing environments, the Eaton BladeUPS® delivers 12 kW of efficient, reliable power in only 6U of standard rack space, including batteries. It also expands capacity by combining 12 kW modules in a building block fashion to deliver 60 kW of redundant backup power from a single rack enclosure. This powerful configuration delivers a higher power density than competitive modular solutions, while dissipating one-third of the heat.

In addition, the standard internal batteries provide needed ride-through power until an auxiliary power source takes over or systems are gracefully shut down. Extended runtime is up to 34 minutes at full load (or 76 minutes at half load) with Extended Battery Modules (EBMs).

### Power protection for:

- Blade servers
- Small, medium and large data centers
- Network closets
- PBX and VoIP equipment
- Networking applications: IPTV, security
- Storage devices: RAID, SAN
- Database clusters

### Features:

- Protects mission-critical applications with innovative backup power technology designed specifically for high-density computing environments
- Supports the constant moves, adds and changes of today's dynamic data centers with a modular, scalable, and flexible backup power architecture
- Conserves valuable rack space with 12 kW of power in only 6U of rack height, including batteries
- Accommodates growth by enabling building-block upgrades from 12 kW to 60 kW in a single rack enclosure
- Reduces energy costs and cooling needs through best-in-class efficiency performance
- Delivers highest levels of reliability at the rack with patented Powerware® Hot Sync® paralleling technology and intelligent bypass design, field proven in thousands of large data centers globally
- Simplifies installation and service with true plug-and-power connections and hot-swappable batteries and electronics modules
- Increases battery life through ABM® technology, resulting in more uptime and fewer battery replacements

# Sustainable by design

To Eaton, sustainability reflects the ability to meet the current needs of society while enabling future generations to better meet their own.

Though all of Eaton's solutions are designed to meet or exceed governmental standards in protecting the environment, the Eaton Green Leaf symbol is our promise, that the solution has been reviewed and documented as offering exceptional environmental benefits and value to the user.

Due to superior environmental performance and features, the BladeUPS among other innovative Eaton solutions, has earned the "An Eaton Green Solution™" label.



---

## An Eaton Green Solution

### An Eaton Green Solution

- **Feature**

- 98 percent energy efficiency
- 65 percent less heat dissipation
- 70 percent reduced footprint
- Scalable, modular and flexible design

- **Customer benefit**

- Best-in-class efficiency
- Lower energy and cooling costs
- Extended battery life
- Reduced product footprint
- Increased reliability and performance
- More capacity

- **Environmental benefit**

- Less energy consumption
- Reduced carbon footprint
- Reduction of hazardous materials



Eaton BladeUPS – 12 kW



IT organisations are forced to make decisions that provide efficient power protection and distribution for growing loads, while managing the heat.

# Reduce energy costs with high efficiency

As utility rates continue to climb, energy efficiency becomes a sticking point with data center managers.

The BladeUPS delivers an outstanding, industry-leading 98 percent efficiency in normal operation. Even at <50% load, where efficiency is typically much lower, this UPS performs more efficiently than competitors' modular products at full load.

In addition to dramatic cost savings, high system efficiency extends battery runtimes and produces cooler operating conditions within the UPS, extending the life of components and increasing overall reliability and performance.

Even small increases in efficiency can quickly translate into thousands of dollars. The example below compares annual and five-year energy costs for the BladeUPS and a competitor's solution. It's easy to see that the BladeUPS pays for itself through energy and cooling savings alone.

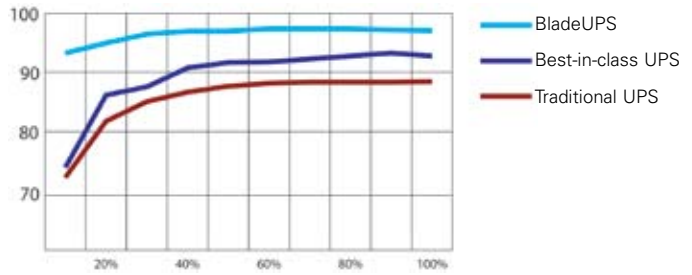

Even at very small loads, where you would expect efficiency to be lower, the Eaton BladeUPS is still more efficient than other UPS products at full load.

## Example

	Eaton BladeUPS	Nominal UPS
UPS Efficiency Rating	>98 percent	91.5 percent
Rack Power Consumption	60 kW	60 kW
Cost per Kilowatt Hour	€ 0.08	€ 0.08
Cost to Operate per Hour	€ 4.94	€ 5,25
Monthly Power Savings	€ 218 Saved Each Month with BladeUPS	
Heat Dissipation (BTUs per hour)	6,300	19,000 (BTUs per hour)
*Monthly Cooling Savings	€ 197 Saved Each Month with BladeUPS	
Annual Savings with BladeUPS	€ 4,990 Saved Each Year BladeUPS	
Five-Year Savings with BladeUPS	€ 24,952 Saved In Five Years	

\* Cooling savings based on industry calculation of cooling costs per kW of power costs.

# Reduce cooling costs with lower heat dissipation

The high-efficiency BladeUPS reduces the power requirements for the data centre. In the example shown, the Eaton BladeUPS reduces energy costs by an average of 218 € per month. In addition, the high efficiency of a Eaton BladeUPS reduces overall air conditioning needs by more than one third, multiply that with a reduction in cooling costs by one-third and utility bills are further decreased by an additional 197 € per month. The savings compound with the data centre size and the number of UPS products. The low heat dissipation means this UPS can be located close to equipment racks without a concern for creating hot spots in the data centre.



The Eaton BladeUPS remains cool even in a data centre full of servers.

# Meet current and changing requirements with modular architecture

The building block of the BladeUPS system is a 6U rackmount module that provides 12 kW of backup power protection. The system expands easily to provide maximum results. As your data center grows, the system's modularity plays a key role in optimizing your capital planning and deployment. Using the patented and field-proven Powerware Hot Sync paralleling technology, up to six BladeUPS modules can be paralleled for extra capacity or redundancy, providing 60 kW of redundant backup power protection in one 19-inch rack.

Patented load-sharing control intelligently distributes the workload among modules without requiring direct synchronization links among them. Any module can provide backup support for any other, with no interruption or downtime. For instance, in a redundant system you could perform full maintenance on any module without any interruption of conditioned power to the protected IT equipment.

## YEAR 1: INITIAL INSTALL



**12 kW**

42U Standard Enclosure

12 kW BladeUPS occupies 6U of space

## YEAR 3: EXPANSION



**36 kW**

BladeUPS Parallel Bar for paralleling UPS modules

Total Rack Space: 24U

Three 12 kW UPS modules = 36 kW of backup power

6U Electrical Wire Way

## YEAR 5: FURTHER EXPANSION



**60 kW, N+1**

Redundant N+1 Configuration: Six 12 kW UPS modules share the load equally. If a UPS module is removed from service, the remaining modules seamlessly support the load without interruption.

The BladeUPS is designed to be extraordinarily flexible—configured as a single module or multi-module system (up to six modules) in a standard 19-inch rack enclosure. The modular design enables you to deploy just the right amount of backup protection at the right price for your current needs and expand later whenever needed.

# Easy setup with simple parallel configuration changes

The BladeUPS is easy to install, configure, and deploy—and easy to expand later, without help from Eaton. To link multiple BladeUPS modules into a parallel configuration, all you need is a BladeUPS Parallel Bar—a simple kit installed in the bottom of the rack and on the back rail. IT personnel can then simply plug additional modules into the parallel bus bar. The system is intelligent, so it automatically detects paralleled modules and fully configures itself for parallel operations.



Adding modules is a simple plug-and-power procedure for IT personnel with safety approved connectors.

Administrators can monitor and manage the BladeUPS using the unit's LCD panel or remote monitoring software. The UPS provides data for the entire multi-module system, as well as the individual module. In addition, a module working in a parallel configuration can be separated at any time and re-deployed as a standalone module to meet a data center's changing requirements.



BladeUPS Parallel Bar

The BladeUPS Parallel Bar easily connects up to six modules in parallel.

## The brightly backlit 6 cm LCD shows parameters of the system or a module.

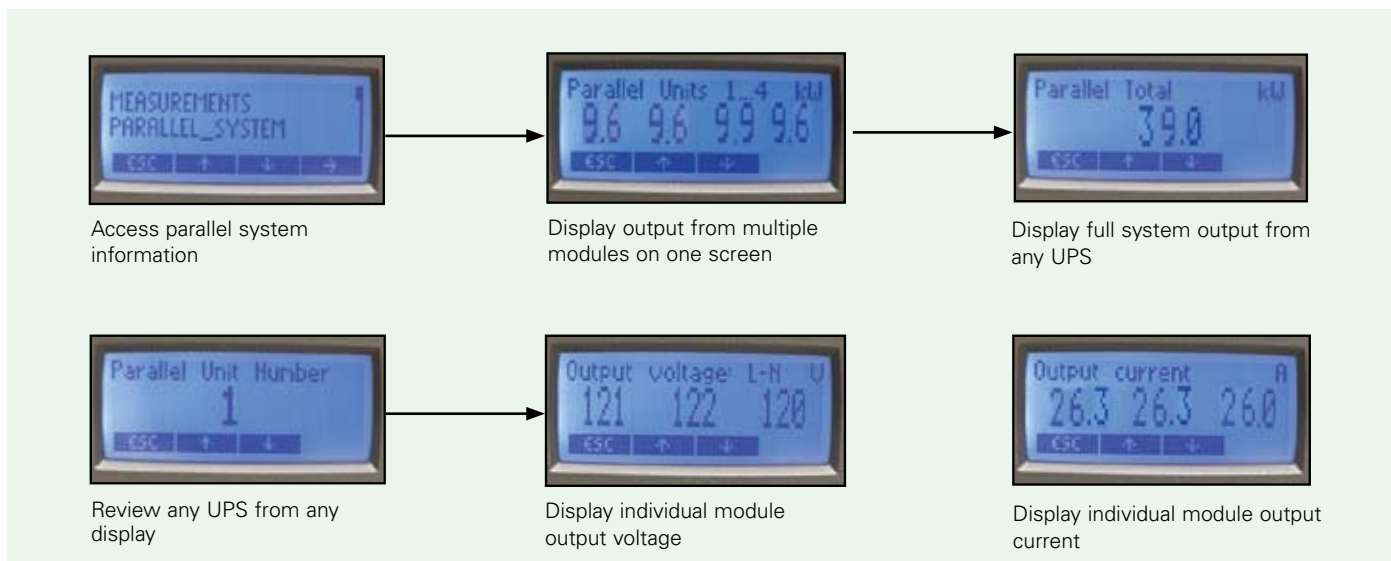

# The smallest footprint in the market

The BladeUPS offers the smallest footprint of any UPS in its class and double the power density of any other UPS system on the market. This compact design leaves extra space for important IT equipment in the rack and data centre.

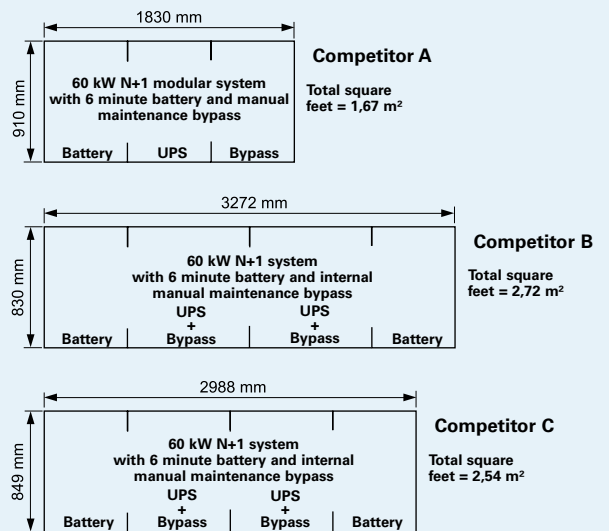
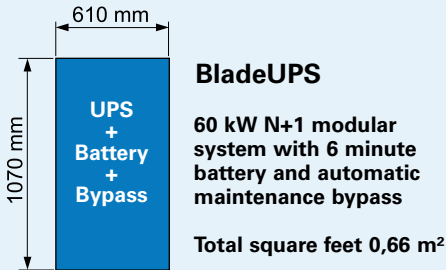

## Expedite deployment with flexible installation options

The BladeUPS can be deployed in a variety of system architectures to support the specific requirement of your computer room or data centre and to support the desired level of redundancy (Tier I through Tier IV, as defined by the Uptime Institute).

**Centralised power protection for small computer rooms.** Start with one 12 kW module and expand to 60 kW with N+1 redundancy in single 19" rack enclosure.

**Zone power protection for mid-sized computer rooms.** Deploy 60 kW (N+1) in a 19" rack to protect a row of IT equipment racks.

**Distributed power protection.** Make 12 kW modules to protect one to three racks—thereby achieving zero footprint power protection.

**Hybrid power protection.** Stronger redundancy of power protection for equipment racks containing critical IT equipment.

- For dual-corded loads with one source on a central UPS and the other on utility power, you can back up selected loads with a local BladeUPS, deployed in a distributed or zone fashion.
- For dual- or single-corded loads on a central UPS, you can back up selected loads with a local BladeUPS (distributed or zone) in series with the central UPS. This configuration provides maximum reliability close to critical loads, with minimal heat dissipation and maximum efficiency.

With the flexibility to deploy and re-deploy a BladeUPS either in single or parallel systems—data centre managers can tailor power protection to adapt to changing needs, often without the need for an electrician or service technician.

Eaton also offers an assortment of plug-and-play power distribution accessories with various input and output connections to distribute power from the BladeUPS to rack power strips or directly to high-power servers. You can choose from distribution designs with or without monitoring capability for redundant or non-redundant applications spanning from zero U to full rack height.

## System Architecture with the BladeUPS

### Centralised Power Protection



### Centralised Power Protection—Dual Power Feeds



### Zone Power Protection



### Distributed Power Protection



### Hybrid Power Protection

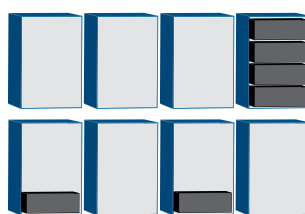

### Central Large UPS

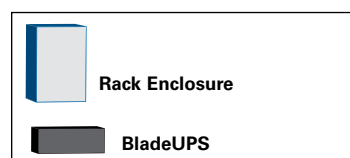

# Count on reliable system performance and uptime

Recognizing the mission-critical nature of data center operations, the BladeUPS has been designed for premium reliability and continuous operation. The rackmount BladeUPS incorporates leading technologies that Eaton developed for its largest UPSs, such as:

**Robust paralleling.** With Eaton's patented Powerware Hot Sync technology, UPS modules work in peer-to-peer fashion when configured in a parallel system. Most other paralleling systems on the market use a single central main controller with a backup controller. If the main controller fails, the system must recognize this and transfer control to the backup control, or the entire system fails. With Eaton's patented approach, each UPS module operates independently, yet is completely synchronized with the others. There is no change in control, therefore no single point of failure.

**Intelligent maintenance bypass switch.** The internal switch inside the UPS chassis automatically activates bypass mode whenever a power module is removed. This feature ensures that power to protected loads is not accidentally interrupted by human error. (If the UPS is in a parallel environment with N+1 redundancy, removing an electronics module only causes that particular UPS module to go offline while the protected equipment is supported by other modules in the configuration).

**Static bypass switch.** All BladeUPS modules have their own static switch for normal operations and for internal bypass in case of a high overload condition, output load fault or internal failure.

**Hot-swappable electronics and battery modules.** Replacing batteries or electronics modules can be done in minutes without interrupting power to IT equipment. This hot-swap capability helps reduce mean time to repair (MTTR) and dramatically improves the availability of the protected IT equipment.

**Eaton's advanced battery management technique.** ABM technology significantly extends battery service life with a unique three-stage charging technique. The UPS automatically tests battery health and provides advance notification when preventive maintenance is needed, allowing ample time to hot-swap batteries without ever having to shut down connected equipment.

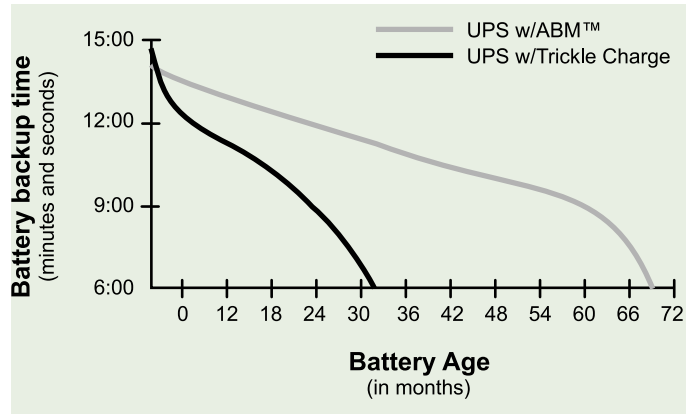

Eaton's ABM technology significantly increases battery service life



IT staff can easily replace battery modules

# Simplify UPS installation and maintenance

The BladeUPS is easy to install, configure and deploy. All BladeUPS modules (UPS and battery) come with rackmount kits for easy installation in standard equipment racks. In-house IT staff can install and service this UPS themselves. Adding parallel units for future expansion is a simple, plug-and-play procedure.

The BladeUPS battery trays are user-replaceable so that one person, working alone, can replace the battery without disrupting data center operations or power to protected equipment.



IT staff can easily install electronics modules



# Easy Power Distribution with ePDU

The BladeUPS core ePDU, the Rack Power Module (RPM), delivers up to 36 kW of single phase power. The 3U RPM can be deployed in the same rack with the BladeUPS and IT equipment, so there is no need for a dedicated infrastructure rack.

The resulting architecture gives great flexibility for IT staff to configure their data centre.

## Features:

- Plug-and-play power distribution from BladeUPS three-phase input, to single phase output for secondary ePDU devices.
- Serves data centre loads with various power cord configurations and layouts
- Distributes power to 12 poles, grouped into two sets of six poles, with combinations of C13 and C19 output socket types
- "Power Equalizer" LED display gives quick visual indication of the load on each circuits, reducing possibility of overloads and breakers tripping.
- Branch circuit monitoring option allows load monitoring over the network.
- Installs in 3U of space in EIA 19" rack or enclosure



Rack Power Module (RPM) delivers up to 36 kW of single phase power.

# Monitor the power infrastructure from anywhere

You can monitor the BladeUPS over your LAN or the Internet to stay informed of conditions in the power protection infrastructure.

With Intelligent Power<sup>®</sup> Manager supervisory software, you get a global view across the network from any PC with an Internet browser. Exceptionally versatile, the software is compatible with power devices supporting a network interface, including other manufacturers' UPSs, environmental sensors, ePDUs, shutdown applications and more.

In the event of an extended power outage, Eaton's free NetWatch software works in conjunction with the ConnectUPS X-Slot<sup>®</sup> Web/SNMP card to allow you to gracefully and sequentially shut down connected devices, including virtual machines.

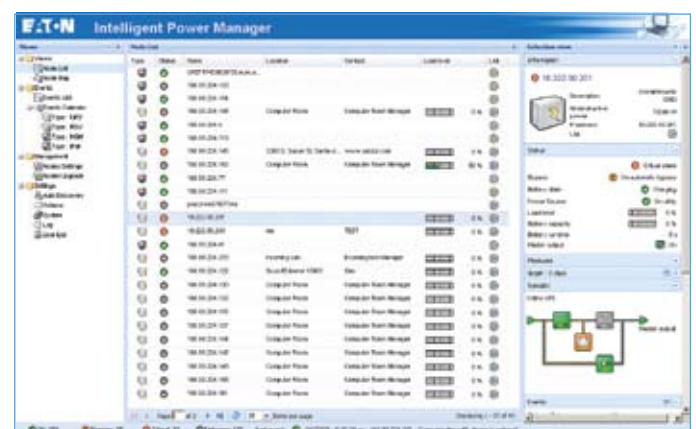

With Intelligent Power Manager, you get a global view across the network from any PC.

# Flexible runtime options

Each BladeUPS can be configured with its own external battery backup. The BladeUPS design eliminates this single point of failure. Competitive, modular systems use a centralized battery bank with a shared connection point that presents a potential single point of failure.



Eaton BladeUPS Extended Battery Module

Load		# 42U Rack	4 kW	8 kW	12 kW	24 kW	36 kW	48 kW	60 kW	
1 x BladeUPS (12 kW Internal battery)	6	6	1	23	8,7	4,7				
+ 1 External Battery Module	9	9	1	41	17,6	9,5				
+ 2 External Battery Module	12	12	1	65	28	17				
+ 3 External Battery Module	15	15	1	93	43	27				
+ 4 External Battery Module	18	18	1	119	55	34				
2 x BladeUPS (12 kW N+1 Internal battery)	12	18	1	44	23	13,6				
+ 1 External Battery Module	18	24	1	85	41	27				
+ 2 External Battery Module	24	30	1	137	65	41				
+ 3 External Battery Module	30	36	1	198	93	59				
+ 4 External Battery Module	36	42	2	257	119	76				
3 x BladeUPS (24 kW N+1 Internal battery)	18	24	1		34	23	8,7			
+ 1 External Battery Module	27	33	1		34	41	17,6			
+ 2 External Battery Module	36	42	2		102	65	28			
+ 3 External Battery Module	45	51	2		147	93	43			
+ 4 External Battery Module	54	60	2		190	119	55			
4 x BladeUPS (36 kW N+1 Internal battery)	24	30	1			30	13,6	7,3		
+ 1 External Battery Module	36	42	2			56	27	14,7		
+ 2 External Battery Module	48	54	2			89	41	24		
+ 3 External Battery Module	60	66	2			128	59	37		
+ 4 External Battery Module	72	78	2			165	76	47		
5 x BladeUPS (48 kW N+1 Internal battery)	30	36	1				19	10	6,6	
+ 1 External Battery Module	45	51	2				34	21	13,3	
+ 2 External Battery Module	60	66	2				54	31	23	
+ 3 External Battery Module	75	81	2				77	48	35	
+ 4 External Battery Module	90	96	3				98	61	44	
6 x BladeUPS (60 kW N+1 Internal battery)	36	42	2				23	13,5	8,7	6,2
+ 1 External Battery Module	54	60	2				41	27	17,6	12,6
+ 2 External Battery Module	72	78	2				65	41	28	21,6
+ 3 External Battery Module	90	96	3				93	59	43	33
+ 4 External Battery Module	108	114	3				119	76	55	42

\* Note: each UPS requires the same number of external batteries

Time in minutes

# BladeUPS Technical Specifications

## TECHNICAL SPECIFICATIONS

### General

Power Rating	12 kW per UPS module
Efficiency	Up to 98 percent
Heat Dissipation	371W/1266 BTU/hr at 100% rated load
Cooling	Fan cooled, temperature microprocessor monitored; front air entry, rear exhaust
Audible Noise, Normal Operation	<60 dBA at 1 meter
Altitude Before Derating	1000 meters (3300 ft ASL)

### Input

Input Voltage	400 Vac
Voltage Range	400V: 311 to 519 Vac, phase to phase
Frequency Range	50 or 60 Hz, $\pm 5$ Hz
Input Current Distortion	<5% with IT loads (PFC power supplies)
Input Power Factor	>0.99 with IT loads (PFC power supplies)
Inrush Current	Load dependent
Input Requirements	Three-phase, four-wire + ground
Bypass Source	Same as input (single feed)
Generator Compatibility	Fast sync slew rate for generator synchronisation

### Output

Rated Output Voltage	400V: 180 to 240 Vac, Ph to N
Output Configuration	Three-phase, four-wire + ground
Output Frequency (nominal)	50 or 60 Hz auto-detection on startup
Frequency Regulation	0.1 Hz free running
Load Power Factor Range	Lagging: 0.7 Leading: 0.9
Total Output Voltage Distortion	<3% with IT loads (PFC power supplies) <5% non-linear or non-PFC power supplies

### Battery

Battery Type	VRLA - AGM
Battery Runtime (Internal)	13 minutes at 50 percent load 4.7 minutes at 100 percent load
Battery String Voltage	240 Vdc
Battery Test	Automatic battery test standard (remote scheduling capable) Manual battery test from front display
Battery Recharge Profile	ABM three-stage charging technology
Battery Cut-off Voltage	Variable from 1.67 VPC at <5 min. runtime
Battery Low Condition	Announced with alarm
Extended Battery Capability	Yes, add up to four additional 3U battery enclosures (~34 min at 100 per cent load, >1 hour at 50 per cent load)

### Physical

Dimensions (HxWxD) UPS	261 (6U) x 442 x 660 mm
Note: Total Chassis Weight without batteries or electronics	46 kg
Total Chassis Weight with batteries or electronics	140 kg
Total UPS Weight without Batteries	61 kg
Total UPS Weight with Batteries	140 kg
EBM Weight	77 kg

### Communications and User Interface

Software Compatibility	UPS ships with Software Suite CD containing LanSafe power management software and a trial version of PowerVision
X-Slot Bays	Two available for the cards listed below
Control Panel LCD	Two lines by 20 characters Four menu-driven interface buttons Four status at a glance LEDs
Multi-language	English standard; 20 languages available
Configuration Changes	User capable, firmware auto configures
Dry Contact Inputs	Two, user-configurable
Dry Contact Outputs	One, user-configurable

### Service

Installation	User capable, located in the IT racks
Preventative Maintenance	User capable, optional factory service available
Corrective Maintenance	User capable, optional factory service available
Serviceability Features	Hot-swappable batteries Hot-swappable electronics module Automated internal maintenance bypass Auto-configure firmware Flash firmware upgradeable

### Certifications

EMI	IEC 62040
Surge Protection	ANSI C62.41, Cat B-3
Hazardous Materials (RoHS)	EU Directive 2002/95/EC Category 3 (4 of 5)

### Warranty

Standard	12 months
Warranty Repair	Factory depot repair or replace

### Options and Accessories

Detachable input cord	
Detachable input/output cord assembly	
Detachable paralleling cord assembly	
Extended Battery Modules (EBMs)	
3U output sub-distribution module	
0U to 3U rack power strips	
60 kW BladeUPS Parallel Bar	
Four-post rail kit	

### Optional X-Slot Communication Cards

Application	Card
Web SNMP	ConnectUPS-X Web/SNMP Card
Environment Monitoring	EMP Environmental Monitoring Probe (requires Web/SNMP card)
Modbus® RTU	Modbus Card
IBM eServer™ (i5™, iSeries™, or AS/400), industrial	Relay Interface Card
Parallel	Powerware Hot Sync Card
Remote LCD Display	ViewUPS-X

### Recommended ePDU:

Y032440CD100000	RPM - Rack Power Module (BladeUPS in, 12xC13 + 6xC19 out) 20 ft lead
PW107BA0UC08	ePDU - Basic (0U, Dual 16A C20 in, 24xC13+ 8xC19 out) use in addition to RPM
PW107MI0UC08	ePDU - IP Monitored (0U, Dual 16A C20 in, 24xC13+ 8xC19 out) use in addition to RPM

Due to continuing product improvement programs, specifications are subject to change without notice.

For assistance with your power quality needs, contact your local Eaton service and sales representatives.

**[www.eaton.com/powerquality](http://www.eaton.com/powerquality)**



Eaton, Powerware, ABM, BladeUPS, ePDU, HotSync, Intelligent Power, LanSafe, PowerVision and An Eaton Green Solutions are trade names, trademarks, and/or service marks of Eaton Corporation or its subsidiaries and affiliates. © 2010 Eaton Corporation. All Rights Reserved.  
00BROC1018033 Rev E March 2010  
[eaton.com/powerquality](http://eaton.com/powerquality)